

未注公差/General tolerances(mm)														
0	>3	>6	>10	>18	>30	>50	>80	>120	>180	>250	>315	>400	>500	0.1/10 ±2'
~3	~6	~10	~18	~30	~50	~80	~120	~180	~250	~315	~400	~500		
±0.12	±0.18	±0.22	±0.26	±0.31	±0.37	±0.57	±0.80	±0.93	±1.05	±1.15	±1.60	±2.20	±2.50	

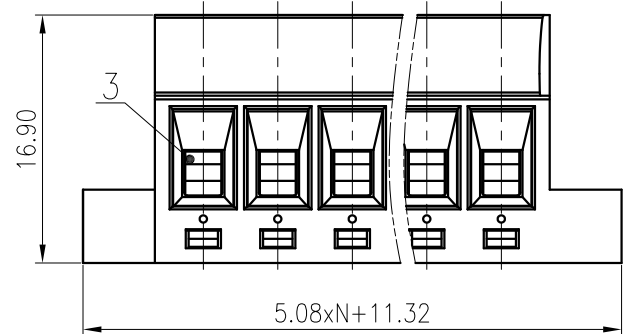
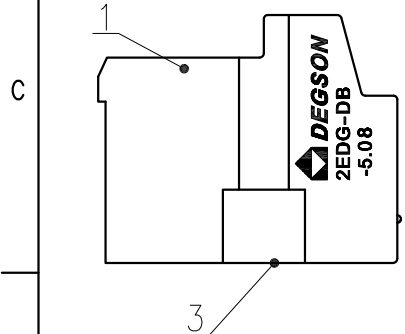
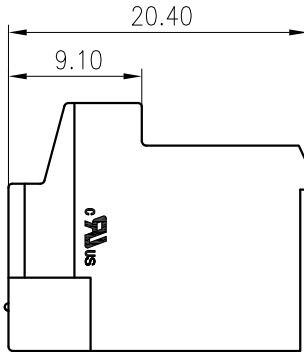
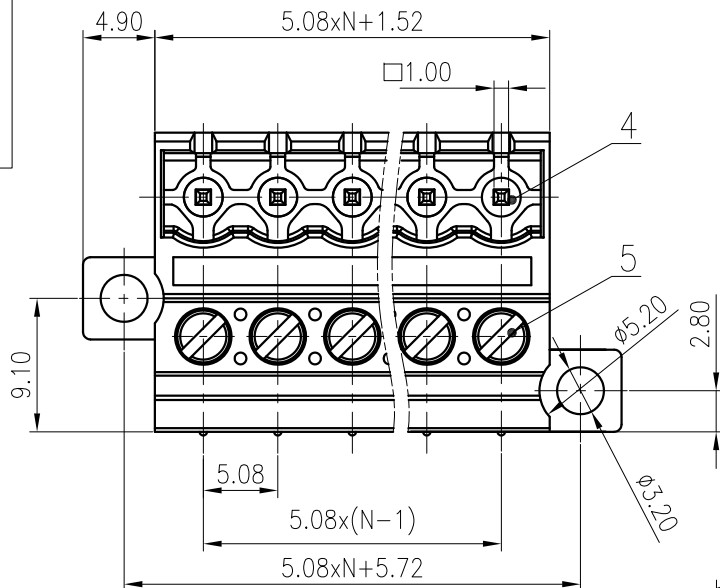
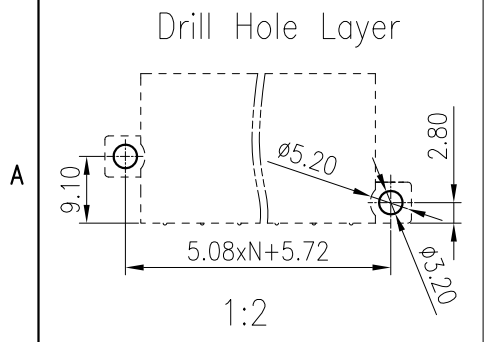

5	Screw	Steel	M3/Zn Plated
4	Pin	Copper	Sn Plated
3	Cage	Copper Alloy	Ni Plated
2	Cover	PA66	UL94V-0
1	Housing	PA66	UL94V-0

ITEM	NAME OF PART	MATERIAL	NOTES
UL 标准/UL Standard:			
额定电压/电流/Rated Voltage(V)/Current(A)		B	C
		300/15	/ 300/10
IEC 标准/IEC Standard:			
过压类别/Overvoltage Category/污染等级/Pollution Degree		III/3	III/2 II/2
额定电压/电流/Rated Voltage(V)/Current(A)		250/12	320/12 630/12
额定脉冲电压(KV)/Rate Impulse Voltage(KV)		4	4 4
螺丝扭矩/Torque Tightening(N·m/Lb.in)		M3, 0.59/5.21	
线径范围(硬线和软线)/Wire Range(rigid and flexible)(mm <sup>2</sup> /AWG)		0.2~2.5/28~12	
间距/Pitch(mm)/线数范围/Poles		5.08/N=02~24P	
剥线长度/Stripping length(mm)		7~8	
使用温度范围/Operating temperature(°C)		-40~+105	
符合RoHS环保要求/Conform to RoHS		Yes	

MATERIAL:	/	SURFACE:	/
MAT NO.:	/	宁波高松电子有限公司 NINGBO DEGSON ELECTRICAL CO., LTD	
STATUS:	/		
APPD: LanChH 2020.05.19			
CHKD: GonYZh 2020.05.19		NAME: 2EDG-DB-5.08-XXP-14-00A(H)	
DRFT:ChenZhM 2020.05.19		DRAWING NO.:	10001971
REV	ECN	DESCRIPTION	DRFT
DATE			
SIZE: A4		TYPE: CUSTOMER DRAWING	SCALE: 2:1
		SHEET	1/1

REV	ECN	DESCRIPTION	DRFT	DATE