

| PITCH RANGE IN MM | | | NOMINAL DIMENSION RANGE IN MM | | | | - |
|----------------------|-------|-------|----------------------------------|-------|-------|-------|---------|
| TO | OVER | OVER | TO | OVER | OVER | OVER | |
| 6 | 6 | 10 | 30 | 30 | 60 | 100 | ∩ |
| 10 | 10 | 24 | 60 | 60 | 100 | 150 | ◇ |
| ±0.10 | ±0.15 | ±0.25 | ±0.20 | ±0.30 | ±0.50 | ±0.70 | ±1.00 |
| | | | | | | | 0.05/10 |

A

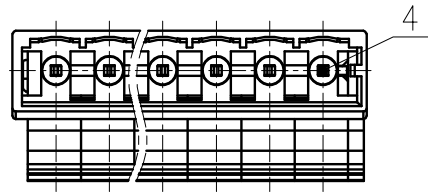

B

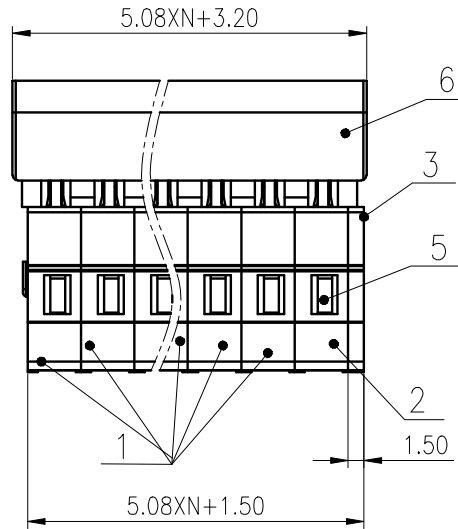
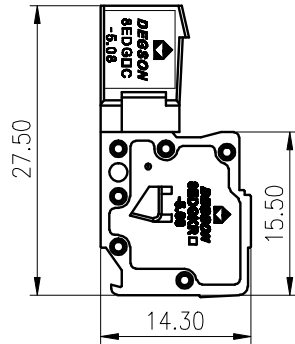

C

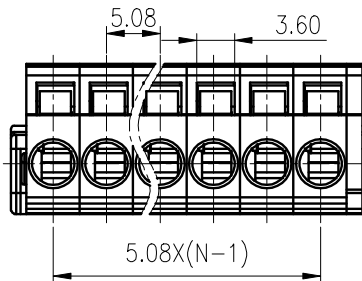

D

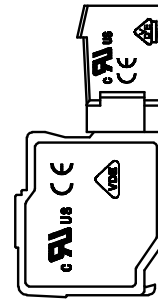
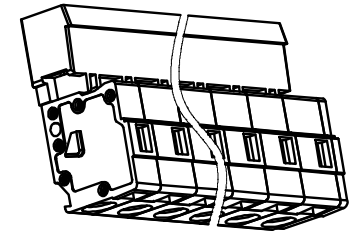

| 6 | Housing2 | PA66 | UL94V-0 |
|--|---------------|-----------------|-----------|
| 5 | Spring | Stainless Steel | |
| 4 | Pin | Copper | Sn Plated |
| 3 | Cover | PA66 | UL94V-0 |
| 2 | Side Housing | PA66 | UL94V-0 |
| 1 | Housing1 | PA66 | UL94V-0 |
| ITEM | NAME OF PART | MATERIAL | NOTES |
| UL 标准/UL Standard: | | | |
| 额定电压/电流/Rated Voltage(V)/Current(A) | 300/15 | / | 300/10 |
| IEC 标准/IEC Standard: | | | |
| 过压类别/Overvoltage Category/污染等级/Pollution Degree | III/3 | III/2 | II/2 |
| 额定电压/电流/Rated Voltage(V)/Current(A) | / | 320/20 | / |
| 额定脉冲电压(kV)/Rate Impulse Voltage(kV) | / | 4 | / |
| 线径范围(硬线和软线)/Wire Range(rigid and flexible)(mm ² /AWG) | 0.2~2.5/22~14 | | |
| 间距/Pitch(mm)/线数范围/Poles | 5.08/N=02~24P | | |
| 剥线长度/Stripping length(mm) | 10 | | |
| 使用温度范围/Operating temperature(°C) | -40~+105 | | |
| 符合RoHS环保要求/Conform to RoHS | Yes | | |
| 标准颜色编号/Standard color number: | PANTONE 7534U | | |
| PANTONE | | | |

| | | | | |
|----------------------|---|------------|-----------|---------------------------|
| MATERIAL: / | SURFACE: / | | | |
| MAT NO.: / | 宁波高松电子有限公司 NINGBO DEGSON ELECTRICAL CO., LTD | | | |
| STATUS: / | | | | |
| APPD: | | | | NAME: |
| CHKD: | | | | 8EDGKR-5.08-XXP-11-01A(H) |
| DRFT: CGM 2018.01.12 | DRAWING NO.: 8EDGKR-5.08-C02 | REV | TO | |
| ⊕ SIZE: A4 | TYPE: CUSTOMER DRAWING | SCALE: 3:2 | SHEET 1/1 | |

| REV | ECN | DESCRIPTION | DRFT | DATE |
|-----|-----|-------------|------|------|
| | | | | |