

REVISION RECORD		REV	ECN	DESCRIPTION	DRFT	DATE

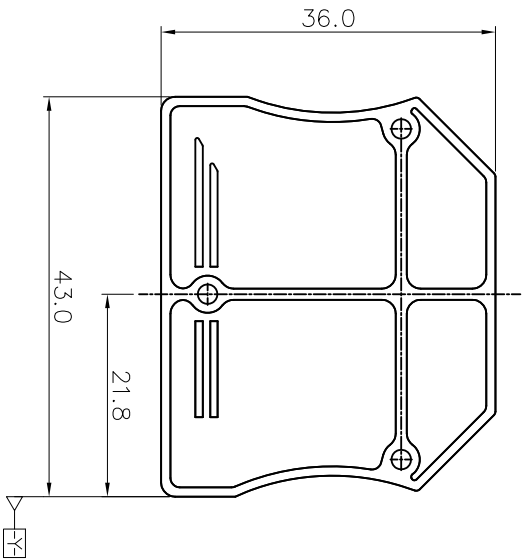
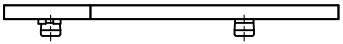
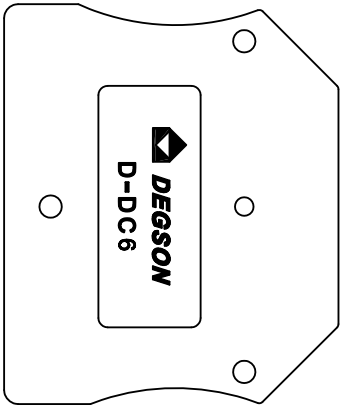
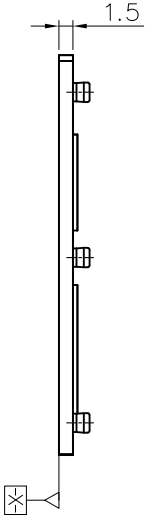

NOTES:

- 1. Dimension shall be interpreted per ASME Y14.5-2009
- 2. Operating temperature: -40°C~+105°C
- 3. Undimensioned tolerances:

Pitch Range		In mm		In mm		In mm		In mm		In mm		
mm	Over	mm	Over	mm	Over	mm	Over	mm	Over	mm	Over	
6	±0.15	6	±0.30	6	±0.50	6	±1.00	10	±0.15	10	±0.30	10
10	±0.20	10	±0.40	10	±0.70	10	±1.40	15	±0.20	15	±0.40	15
24	±0.25	24	±0.50	24	±1.00	24	±2.00	30	±0.30	30	±0.60	30

4. RoHS Compliance

DETACHED LISTS				THIRD ANGLE PROJECTION	
PART NO.:		NAME:		DRAWING NO.:	
APPD:		CHKD:		DRFT:	
CHKD:		NAME:		DO NOT SCALE DRAWING	
DRFT:		D-DCC6-01P--1Y-00A(H)		SCALE	
TITLE: CUSTOMER DRAWING		NINGBO DEGSON ELECTRICAL CO., LTD		REV	
DRAWING NO.:		宁波高松电子有限公司		SHEET	
(MM)				1/1	
(INCH)				DO	
				1 : 1	