

未注公差/General tolerances(mm)											D 0.1/10		
0 ~ 3	>3 ~ 6	>6 ~ 10	>10 ~ 18	>18 ~ 30	>30 ~ 50	>50 ~ 80	>80 ~ 120	>120 ~ 180	>180 ~ 250	>250 ~ 315		>315 ~ 400	>400 ~ 500
											±2'		

A

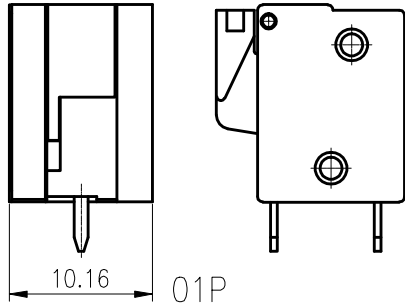

B

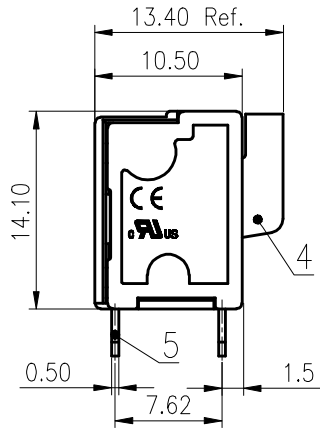

C

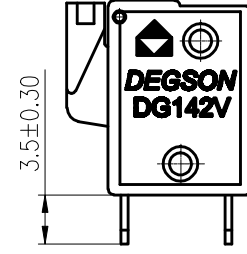
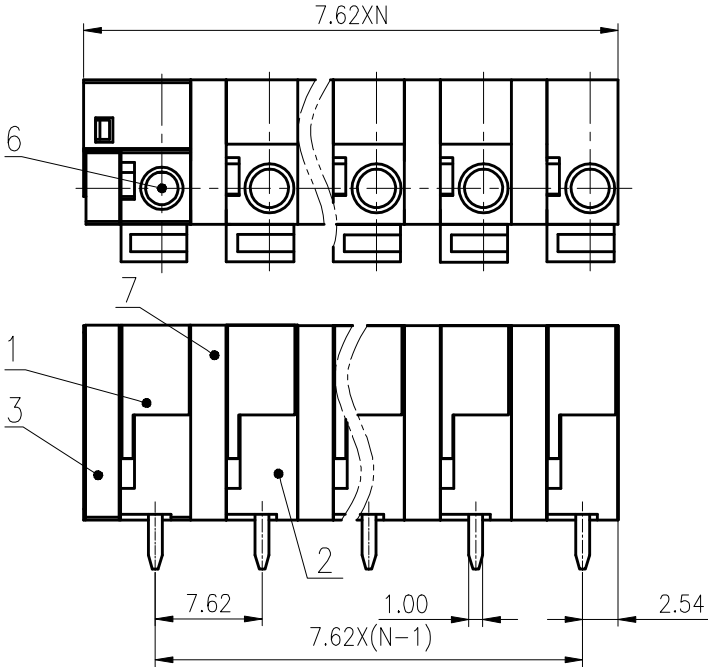

D

7	Clapboard	PA66	UL94V-0
6	Spring	Stainless steel	/
5	Pin header	Copper alloy	Sn Plated
4	Button	PA66	UL94V-0
3	Cover	PA66	UL94V-0
2	Housing 2	PA66	UL94V-0
1	Housing 1	PA66	UL94V-0
ITEM	NAME OF PART	MATERIAL	NOTES

REV	ECN	DESCRIPTION	DRFT	DATE
-----	-----	-------------	------	------

PCB LAYOUT
7.62X(N-1)

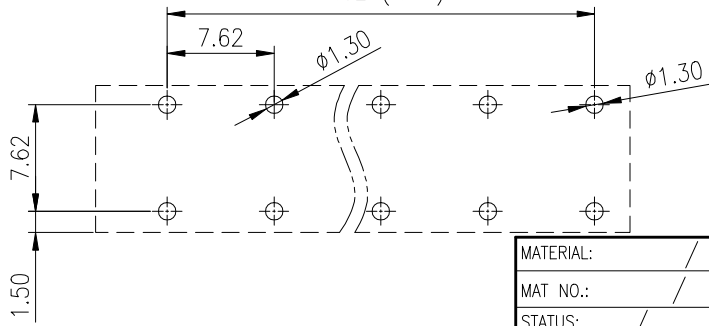

UL 标准/UL Standard:	B	C	D
额定电压/电流/Rated Voltage(V)/Current(A)	300/10	300/10	300/10
IEC 标准/IEC Standard:			
过压类别/Overvoltage Category/污染等级/Pollution Degree	Ⅲ/3	Ⅲ/2	Ⅱ/2
额定电压/电流/Rated Voltage(V)/Current(A)	320/15	320/15	630/15
额定脉冲电压(kV)/Rate Impulse Voltage(kV)	4	4	4
线径范围(硬线和软线)/Wire Range(rigid and flexible)(mm ² /AWG)	0.2~1.5/22~16		
间距/Pitch(mm)/线数范围/Poles	7.62/N=02~16P		
剥线长度/Stripping length(mm)	10		
使用温度范围/Operating temperature(°C)	-40~+105		
符合RoHS环保要求/Conform to RoHS	Yes		
标准颜色编号/Standard color number: PANTONE / RAL	/		

MATERIAL: /	SURFACE: /		
MAT NO.: /	宁波高松电子有限公司 NINGBO DEGSON ELECTRICAL CO., LTD		
STATUS: /			
APPD: LiGL 2020.05.22	NAME: DG142V-7.62-XXP-1Y-1000A(H)		
CHKD: Mek 2020.05.22	DRAWING NO.: DG142V-7.62-C15		
DRFT: LDD 2015.12.14	REV	T2	
SIZE: A4 SCALE: 2:1 SHEET 1/1	TYPE: CUSTOMER DRAWING		