

| 公差/General tolerances(mm) |       |       |       |       |       |       |       |       |       |       | 0.1/10<br>±2' |       |       |
|---------------------------|-------|-------|-------|-------|-------|-------|-------|-------|-------|-------|---------------|-------|-------|
| 0                         | >3    | >6    | >10   | >18   | >30   | >50   | >80   | >120  | >180  | >250  |               | >315  | >400  |
| ~3                        | ~6    | ~10   | ~18   | ~30   | ~50   | ~80   | ~120  | ~180  | ~250  | ~315  | ~400          | ~500  | ~2.50 |
| ±0.12                     | ±0.18 | ±0.22 | ±0.26 | ±0.31 | ±0.37 | ±0.57 | ±0.80 | ±0.93 | ±1.05 | ±1.15 | ±1.60         | ±2.20 | ±2.50 |

A

B

C

D

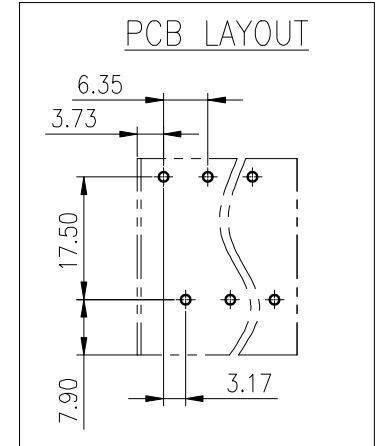
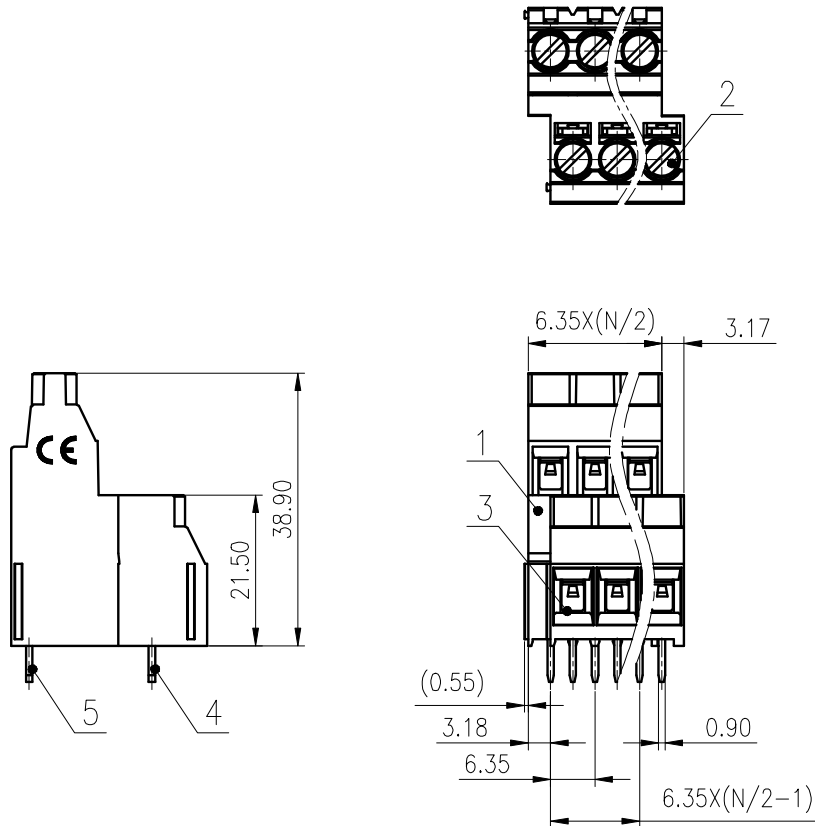

| ITEM   | NAME OF PART | MATERIAL       | NOTES          |
|--|--------------|----------------|----------------|
| 5  | Pin header 2 | Copper         | Sn Plated      |
| 4  | Pin header 1 | Copper         | Sn Plated      |
| 3  | Cage         | Copper alloy   | M3.5/Ni Plated |
| 2  | Screw        | Steel          | M3.5/Zn Plated |
| 1  | Housing      | PA66           | UL94V-0        |
| UL 标准/UL Standard:   |              | B              | C              |
| 额定电压/电流/Rated Voltage(V)/Current(A)                              |              | 300/30         | 300/10         |
| IEC 标准/IEC Standard:   |              |                |                |
| 过压类别/Overvoltage Category/污染等级/Pollution Degree                  |              | III/3          | III/2          |
| 额定电压/电流/Rated Voltage(V)/Current(A)                              |              | 500/32         | 630/32         |
| 额定脉冲电压(kV)/Rate Impulse Voltage(KV)                              |              | 6              | 6              |
| 螺丝扭矩/Torque Tightening(N·m/Lb.in)                                |              | M3.5, 0.8/7.02 |                |
| 线径范围(硬线和软线)/Wire Range(rigid and flexible)(mm <sup>2</sup> /AWG) |              | 0.2~6.0/30~10  |                |
| 间距/Pitch(mm)/线数范围/Poles  |              | 6.35/N=04~48P  |                |
| 剥线长度/Stripping length(mm)  |              | 7-8            |                |
| 使用温度范围/Operating temperature(°C)                                 |              | -40~+105       |                |
| 符合RoHS环保要求/Conform to RoHS                                       |              | Yes            |                |

|                          |   |                        |                      |
|--------------------------|---|------------------------|----------------------|
| MATERIAL:                | SURFACE:  |                        |                      |
| MAT NO.:                 | /   |                        |                      |
| STATUS:                  | /   |                        |                      |
| APPD: Lan ChH 2020.05.15 | NAME: 宁波高松电子有限公司<br>NINGBO DEGSON ELECTRICAL CO., LTD |                        |                      |
| CHKD: Yu JZh 2020.05.15  | DG636A-6.35-XXP-1Y-00A(H)                             |                        |                      |
| DRFT: GYZ 2016.03.24     | DRAWING NO.: DG636A-6.35-C01                          |                        | REV T1               |
| ④                        | SIZE: A4  | TYPE: CUSTOMER DRAWING | SCALE: 1:1 SHEET 1/1 |

| REV | ECN | DESCRIPTION | DRFT | DATE |
|-----|-----|-------------|------|------|
|     |     |             |      |      |