

未注公差/General tolerances (mm)												D 0.1/10		
0	>3	>6	>10	>18	>30	>50	>80	>120	>180	>250	>315		>400	>500
~3	~6	~10	~18	~30	~50	~80	~120	~180	~250	~315	~400	~500	>500	
±0.12	±0.18	±0.22	±0.26	±0.31	±0.37	±0.57	±0.80	±0.93	±1.05	±1.15	±1.60	±2.20	±2.50	±2'

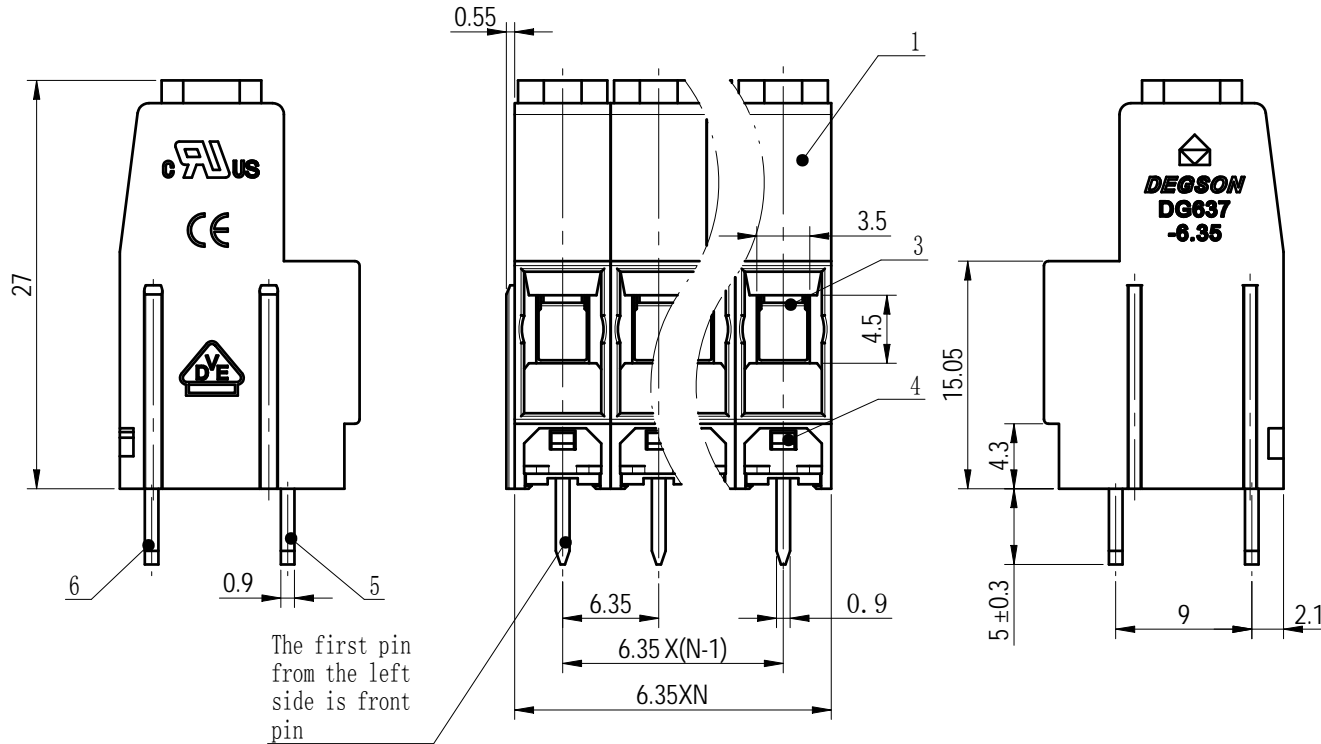
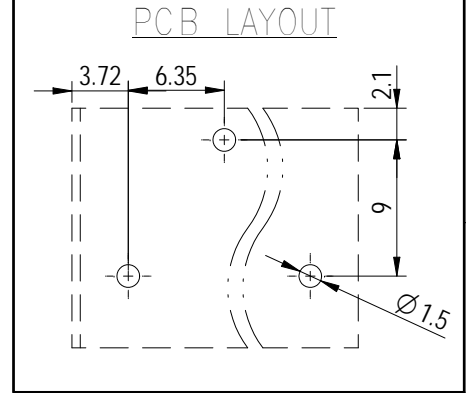
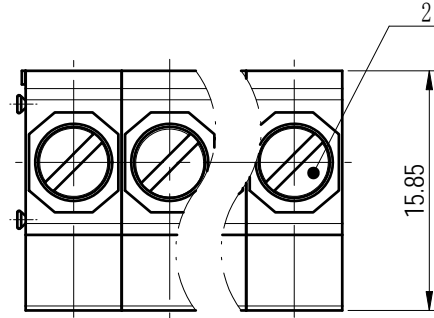

The first pin from the left side is front pin

ITEM	NAME OF PART	MATERIAL	NOTES
6	After pin header	Copper	Sn Plated
5	Front pin header	Copper	Sn Plated
4	Cover	PA66	UL94V-0
3	Cage	Copper alloy	M3/Ni Plated
2	Screw	Steel	M3/Zn Plated
1	Housing	PA66	UL94V-0

UL 标准/UL Standard:	B	C	D
额定电压/电压/Rated Voltage(V)/Current(A)	600V/30	600V/30	600V/5
IEC 标准/IEC Standard:			
过压类别/Overvoltage Category/污染等级/Pollution Degree	III/3	III/2	II/2
额定电压/电压/Rated Voltage(V)/Current(A)	500/20	630/20	1000/20
额定脉冲电压(KV)/Rate Impulse Voltage(KV)	8	8	8
螺丝扭矩/Torque Tightening(N·m/Lb.in)	M3, 0.5/5.0		
线径范围(硬线和软线)/Wire Range(rigid and flexible)(AWG/mm²)	28~10 / 0.2~4.0		
间距/Pitch(mm)/线数范围/Poles	6.35/N=02~16P		
剥线长度/Stripping length(mm)	7~8		
使用温度范围/Operating temperature(°C)	-40~+105		
符合RoHS环保要求/Conform to RoHS	Yes		



MATERIAL:	SURFACE/COLOR:
MAT NO./REV: 10040004040-1 / 00	MAT STATUS: 批量

APPD: 兰春华	2022.05.18	NAME	DRAWING NO. 200071460 TYPE CUSTOMER DRAWING DRAWING STATUS 已发布 SCALE 2:1 SHEET 1/1			
CHKD: 陈招	2022.05.18					
DRFT: 龚徐涛	2022.05.18					

REV	ECN	DESCRIPTION	DRFT	DATE
00		T0版升为00版	龚徐涛	2022.05.18

①	②	A4	(inch)
---	---	----	--------

Transfer or duplication of this document as well as the utilization or communication of its content are prohibited unless authorization is granted. Violations will be held for compensation. All rights reserved for patent, utility model or design registrations. 除专利等明确标注外, 其他标注均非, 否则禁止非法、复制、仿用、分发本文件的任何部分。未经授权的复制或分发, 公司将保留追究法律责任的权利。